

# FN 110

FOR FLOORS – SURFACE FIXING

# MIGUTEC

JOINT COVERS FOR EXPANSION JOINTS

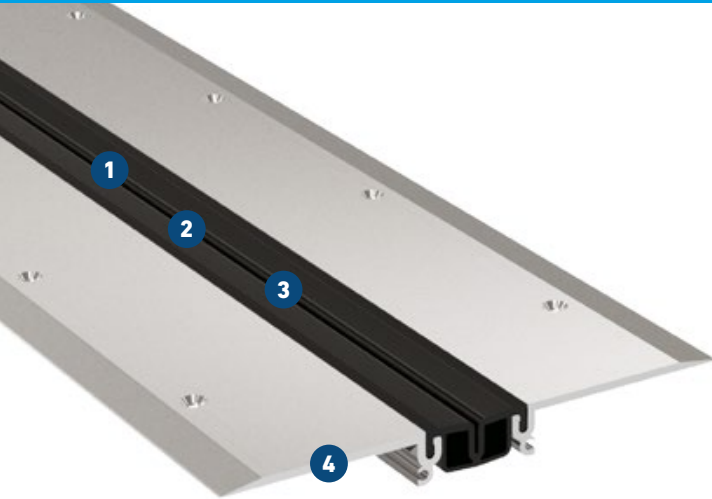

- 1 Anti slip surface ensures good skid resistance**  
Special striated surface, also suitable for sports areas
- 2 Flexible MIGUFLEX insert**  
Hard wearing, temperature resistant (-30°C to +120°C)
- 3 Economical**  
Insert replaceable at any time
- 4 Very flat design**  
Perfect for surface fixing

Expansion joint cover	Total movement $\Delta b_f$ [mm]	Total width $b_t$ [mm]	Joint width required $b_f \text{ min}$ [mm]	Width of insert $b_s$ [mm]	Installation height $h$ [mm]	Thickness of alu side plates [mm]	Load bearing capacity  [kN]
FN 110	60 ( $\pm 30$ )	311	75	64	40	6,3	35

**Installation instructions:** Any unevenness in the surface to which the joint cover is being fixed must be remedied by using an epoxy adhesive e.g. Reckli-Adhesive EP. Thereafter the aluminium brackets must be fixed on both sides with countersunk stainless steel screws e.g. Multi Monti type MMS-7,5 ES or similar, at 200 mm intervals.

**Production length:** 4 m  
**Standard colour:** black  
**Wall connections:** E3, E4

